



Partner in weighing & automation

HIGH-SPEED ONLINE CHECK WEIGHER

MODEL: AW – CWS - B3 SERIES

LCS Controls, we measure accurate

We, LCS Controls is a leading manufacturer of industrial weighing and Customized Solution Partner. Our mission is to increase the reliability, safety, and efficiency of our customers' production processes.

- ✓ B3 Series is an Hi-speed Check weigher system
- ✓ High Accuracy with Reliable performance
- ✓ Easy to install and Easy to operate – very user friendly
- ✓ Model approved by Weights & Measures Department.
- ✓ Proud to be a MAKE IN INDIA product
- ✓ We provide high-quality products, solutions, and services that ensure a high level of safety all under one roof now, a total one-stop solution provider for all. .
- ✓ We are an ISO 9001:2015 certified company



Model : B3



Our strong Domestic and global presence and an extensive network of distribution partners ensure that our customers can rely on top LCS Controls Product quality– anytime, anywhere. Our strong standards in all areas of our company, which is reflected in our brand slogan, **“Your Partner in Weighing and Automation”**.

High-speed Online Check weigher - B3

HIGH-SPEED ONLINE CHECK WEIGHER

MODEL: AW – CWS - B3 SERIES

Products can be handled

- ✓ Bottle / Cream Tubes Packing Lines
- ✓ Packed Carton Boxes
- ✓ Flat Base Bottles
- ✓ Pouches / Sachets
- ✓ Edible Oil Cans / Bottles
- ✓ FFS Machines Lines
- ✓ Liquid Filling Lines
- ✓ Retrofit lines for FFS /
- ✓ Shrink Wrap M/C's
- ✓ Lube Oil Filling Lines
- ✓ High speed measuring lines & etc..

Industries we served



FMCG's



Pharma Industries



Edible Oil / Petrochemicals

Product specifications :

Product Description	Specifications
MOC	SS / MS
Weighing Range	50gm to 5Kg
Weigh Belt size	L: 400 x W: 300mm
Best Accuracy	+/- 3gm
Measuring Product size	Min Size: L: 100mm x W: 100mm / Max Size: L: 250mm x W: 300mm
Max Throughput (Speed)	Upto 80 PPM
Conveyor Height	750mm +/-50mm
Alarm Type	Visual and Alarm
Rejection Type	Air jet, Pusher, Divertor, Drop down..,

Products can be handle on B3 model



Packaging / Pouches/Sachets



SOAP / Tubes / Pouches



Oil Filling Machine



Lube / Grease Filling Line

GA Diagram for B3 series - High speed Online checkweigher

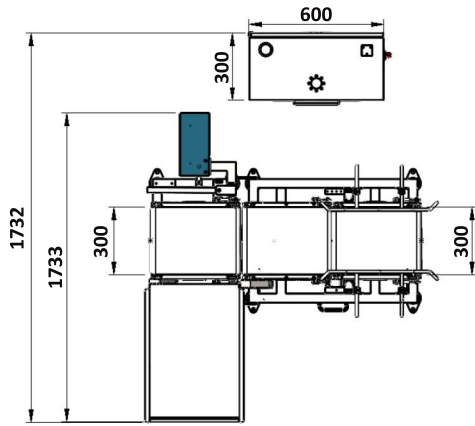

PLAN

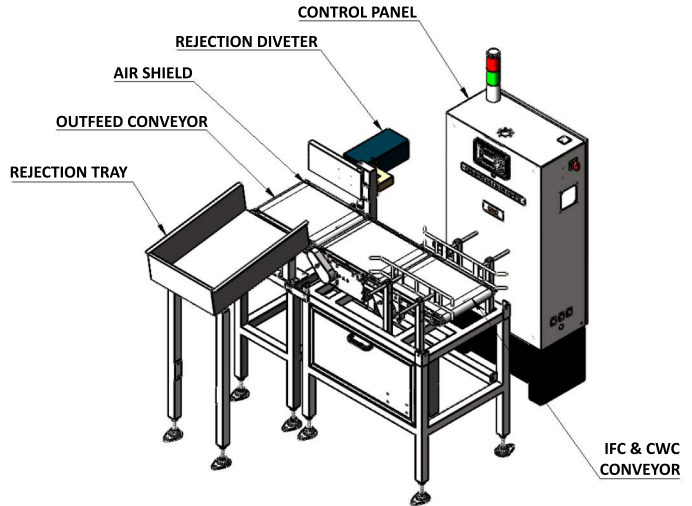

ISOMETRIC VIEW

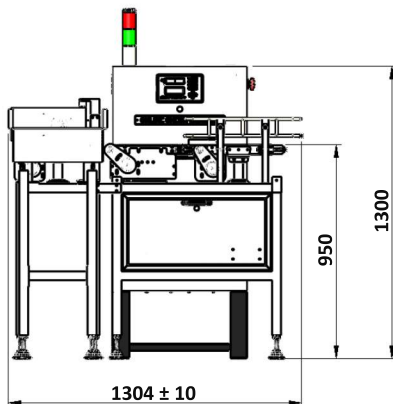

ELEVATION

GA OF B3 CHECKWEIGHER WITH DIVERTER

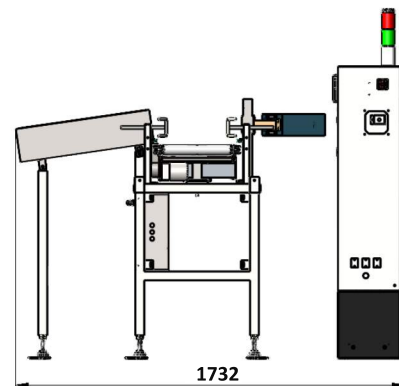

SIDE VIEW

High-speed Online Checkweigher - AW – CWS - B3 SERIES

Product selection guide with part-code for the B3 series checkweigher

CHECKWEIGHER WITH CONTROL PANEL	AIR-SHIELD	CHECKWEIGHER WITH CONTROL PANEL & IN-FEED CONVEYOR	OUT-FEED CONVEYOR	TOUCH SCREEN ONLINE DATA ACQUISITION	REJECTION COLLECTION	REJECTION TYPE	
B3A0-CP-SF B3 CW_PU MS BELT CONVEYOR WITH CONTROL PANEL AND BASE FRAME	B3AS10 B3 MS_ACRYLIC AIRSHIELD	B3A0-CP-IF-DF BB3 IFC_PU MS BELT CONVEYOR WITH CONTROL PANEL AND INFEEDCONVEYOR & INTEGRATED BASE FRAME	B3OBA0-BF B3 OFC_PU MS BELT CONVEYOR WITH BASE FRAME	TS7 7" TOUCH SCREEN – ONLINE DATA ACQUISITION SYSTEM	B3RT0 B3 MS_REJECTION COLLECTION TRAY	B3ERP0 B3 MS_REJECTION PUSHER EXTERNAL_300 MM	B3ERP2 B3 SS316_REJECTION PUSHER EXTERNAL_300MM
B3B0-CP-SF B3 CW_PVC MS BELT CONVEYOR WITH CONTROL PANEL AND BASE FRAME	B3AS20 B3 MS_ALU AIRSHIELD WITH OPEN CLOSE	B3B0-CP-IF-DF B3 IFC_PVC MS BELT CONVEYOR WITH CONTROL PANEL AND INFEED CONVEYOR & INTEGRATED BASE FRAME	B3OBB0-BF B3 OFC_PVC MS BELT CONVEYOR WITH BASE FRAME	TS15 15" TOUCH SCREEN – ONLINE DATA ACQUISITION SYSTEM	B3RB0 B3 MS_REJECTION COLLECTION BIN	B3RD10 B3 MS_REJECTION DIVERTOR MECHANISM	B3RD12 B3 SS316_REJECTION DIVERTOR MECHANISM
B3A1-CP-SF B3 CW_PU SS304 BELT CONVEYOR WITH CONTROL PANEL AND BASE FRAME	B3AS11 B3 SS304_ACRYLIC AIRSHIELD	B3A1-CP-IF-DF B3 IFC_PU SS304 BELT CONVEYOR WITH CONTROL PANEL AND INFEED CONVEYOR & INTEGRATED BASE FRAME	B3OBA1-BF B3 OFC_PU SS304 BELT CONVEYOR WITH BASE FRAME		B3RT1 B3 SS304_REJECTION COLLECTION TRAY	B3RAJ0 B3 MS_REJECTION AIRJET MECHANISM	B3RAJ2 B3 SS316_REJECTION AIRJET MECHANISM
B3B3-CP-SF B3 CW_PVC SS304 BELT CONVEYOR WITH CONTROL PANEL AND BASE FRAME	B3AS21 B3 SS304_ALU AIRSHIELD WITH OPEN CLOSE	B3B3-CP-IF-DF B3 IFC_PU SS316 BELT CONVEYOR WITH CONTROL PANEL AND INFEED CONVEYOR & INTEGRATED BASE FRAME	B3OBB3-BF B3 OFC_PVC SS304 BELT CONVEYOR WITH BASE FRAME		B3RB1 B3 SS304_REJECTION COLLECTION BIN	B3OBD0 B3 MS OF PVC BELT CONVEYOR WITH DROP DOWN MECHANISM	B3OBDA2 B3 SS316 OF PU BELT CONVEYOR WITH DROP DOWN MECHANISM
B3A2-CP-SF B3 CW_PU SS316 BELT CONVEYOR WITH CONTROL PANEL AND BASE FRAME	B3AS12 B3 SS316_ACRYLIC AIRSHIELD	B3A2-CP-IF-DF B3 IFC_PU SS316 BELT CONVEYOR WITH CONTROL PANEL AND INFEED CONVEYOR & INTEGRATED BASE FRAME	B3OBA2-BF B3 OFC_PU SS316 BELT CONVEYOR WITH BASE FRAME		B3RT2 B3 SS316_REJECTION COLLECTION TRAY	B3OBDA0 B3 MS OF PU BELT CONVEYOR WITH DROP DOWN MECHANISM	B3OBD0 B3 SS316 OF PVC BELT CONVEYOR WITH DROP DOWN MECHANISM
B3B2-CP-SF B3 CW_PVC SS316 BELT CONVEYOR WITH CONTROL PANEL AND BASE FRAME	B3AS22 B3 SS316_ALU AIRSHIELD WITH OPEN CLOSE	B3B2-CP-IF-DF B3 IFC_PVC SS316 BELT CONVEYOR WITH CONTROL PANEL AND INFEED CONVEYOR & INTEGRATED BASE FRAME	B3OBB2-BF B3 OFC_PVC SS316 BELT CONVEYOR WITH BASE FRAME		B3RB2 B3 SS316_REJECTION COLLECTION BIN	B3ERP1 B3 SS304_REJECTION PUSHER EXTERNAL_300MM	
						B3RD11 B3 SS304_REJECTION DIVERTOR MECHANISM	
						B3RAJ1 B3 SS304_REJECTION AIRJET MECHANISM	
					B3OBDA1 B3 SS304 OF PU BELT CONVEYOR WITH DROP/DOWN MECHANISM		
					B3OBD0 B3 SS304 OF PVC BELT CONVEYOR WITH DROP DOWN MECHANISM		

Typical Order selection guide :

Selection guide 1: **CHECKWEIGHER WITH CONTROL PANEL (PU BELT)** → **B3A0-CP-SF**

Selection guide 2: **CHECKWEIGHER INFEED CONVEYOR** → **B3A0-CP-IF-DF** | **AIR SHIELD** → **B3AS10** | **OUT FEED CONVEYOR** → **B3OBA0-BF** | **REJECTION COLLECTION** → **B3RT0** | **OUT FEED CONVEYOR** → **B3RD10**

Please select the required product Code and Send to us for the quotation

Our Email address : sales@lcscontrols.in



LCS Controls Private Limited
 34 & 35, First link street, Nehru Nagar, off Rajiv Gandhi Salai, Kottivakkam, Chennai - 600 041, India.
 Phone : +91-44-24542510
 Mobile : +91-94440 24124 / 24125 / 24537, +91-94450 62898
 E Mail : sales@lcscontrols.in Website : www.lcscontrols.in

Singapore office
LCS Controls Pte Ltd
 No: 10, Ubi Crescent #03-37 Ubi Techpark Lobby C, Singapore - 408564.
 Phone : +65 66522831 Mobile : +65 8113 1946
 E Mail : sales@lcscon.com Website: www.lcscon.com

Scan the QR code to view this product on our website

